

Measuring Microphones, Studio Microphones, Hydrophones and Accessory Equipment

type 4221

FEATURES:

- Sound Pressure up to 164 dB (172 dB using tone bursts)
- Frequency range up to 1 kHz with high pressure coupler
- Frequency range down to 1 mHz with low frequency coupler
- Low acoustic impedance makes sound pressure in coupler independent of coupler volume, atmospheric pressure and the influence of adiabatic or isothermic conditions
- Very low vibration level
- Well suited for work in pressurized chambers
- Three coupler configurations, all individually calibrated

USES:

- Measurements on microphones and other pressure transducers at high dynamic pressures and at low frequencies, for instance to determine:
 - Sensitivity
 - Frequency response
 - Distortion
 - and
 - Linearity

The High Pressure Microphone Calibrator Type 4221 allows easy calibration, both absolute and by comparison, of condenser microphones and other pressure transducers at dynamic pressures as high as 172 dB re 20 μ Pa. In addition, it allows measurement down to extremely low frequencies, theoretically to static pressure. Typical

High Pressure Microphone Calibrator



measurements that can be made are sensitivity, frequency response, distortion and linearity.

The high sound pressure is generated in a closed coupler, having a small volume (high acoustic impedance), by a piston moved by an electrodynamic exciter. In order to give the complete exciting system a low acoustic impedance, the piston area is made large, the entire moving system is made with a small mass and the exciter is equipped with soft flexures. The system resonance is about 95 Hz. The low acoustic impedance of the exciting system compared with the high impedance of the coupler, ensures that the sound pressure generated in the coupler depends only on the piston area and on the force produced by the electrodynamic system, which is proportional to the current supplied to the drive coil. This current can easily be measured and held constant. The sound pressure gener-

ated in the coupler is thus independent of:

- Variation of coupler volume
- Variation of atmospheric pressure
- Impedance variation when the process changes from being adiabatic to isothermic at low frequencies
- Non-linearity in load impedance at high dynamic pressures caused by too big volume changes compared to the coupler volume.

The advantages of this system can be fully appreciated when comparing it to a pistonphone, which is a constant volume displacement system where the pressure inside the coupler is influenced by all these parameters.

Due to the very high ratio between the mass of the exciter body and the mass of the moving element (150:1) and because of the

very small piston amplitude (2 to $3\mu\text{m}$ at 154 dB SPL) the vibration level at the position of the microphone is very small. This is an important feature when testing transducers with low acoustic sensitivity as it, in many cases, is combined with a relatively high sensitivity to mechanical vibrations.

The Calibrator is a small, compact, rugged unit and is delivered with adaptors allowing direct calibration of all types and sizes of Brüel & Kjær condenser microphones. Other pressure transducers may be tested by using appropriate adaptors. For measurements on transducers used under high static pressures, the whole unit will work with negligible changes in specifications even under very high pressures, for instance in a pressure chamber.

Description

The complete system consists of the pressure exciter with piston and one of the two couplers which are included; a high pressure coupler and a low frequency coupler. A cross-sectional drawing of the system fitted with the high pressure coupler is shown in Fig.1. As can be seen, the piston surface is plane with the exciter body. A 0.12 mm thick silicone rubber membrane, fixed to both the body and the piston and clamped at the edge of the housing by means of an O-ring, makes the complete system airtight.

The coupler is mounted on the top of the system by means of a threaded locking ring. With the low frequency coupler, the connection is made airtight by means of another O-ring, while the membrane itself serves as gasket with the high pressure coupler.

The input to the drive coil is through a BNC socket via a pre-adjusted resistor. The voltage across this resistor can be measured at another BNC socket.

When delivered, the system is calibrated to give 20 Pa in the coupler per mV across this resistor.

High Pressure Coupler

The volume of the High Pressure Coupler has been made as small as 2 cm^3 , in order to obtain a wide frequency range (high resonant fre-

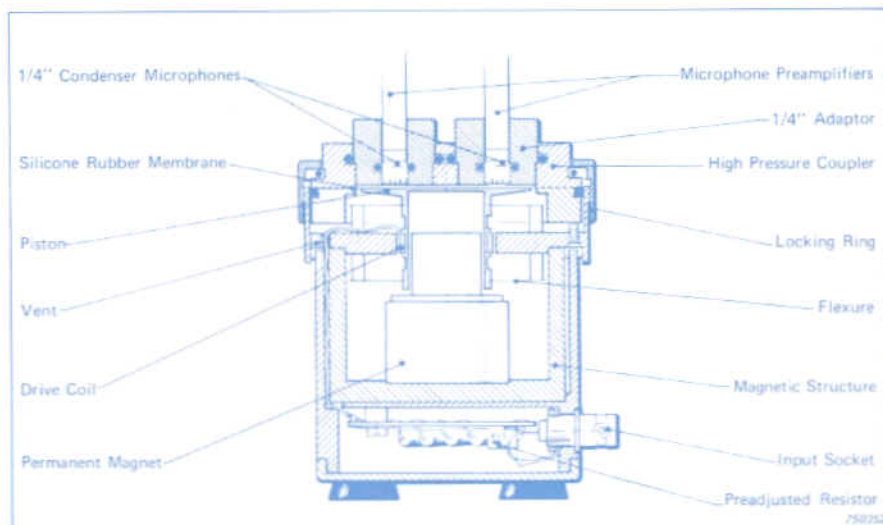

Fig.1. Sectional drawing of the calibrator fitted with the high pressure coupler and two 1/4" condenser microphones

quency). The coupler has two openings, each accepting 1" B & K condenser microphones directly, while 1/2", 1/4" and 1/8" microphones can be inserted as desired in each opening by use of adaptors, which are included. If measurement on only one microphone is desired, one of the openings can be sealed by an adaptor, also included. The microphone with preamplifier is held in place by a spring arrangement. (See Fig.2). The high pressure coupler can be used in two modes: closed (undamped) or partly open (damped). The damping is obtained by loosening two hollow screws, each containing a disc of a sintered material, which act as acoustic resistors. Hereby the pressure increase at resonance is attenuated and the useful frequency range extended upwards. With the screws tightened, closed coupler, it is up to 300 Hz, while it is up to 1 kHz when the damping is introduced.



Fig.2. The High Pressure Calibrator set-up with two condenser microphones for comparison measurements

Fig.3 shows typical pressure response curves for the coupler.

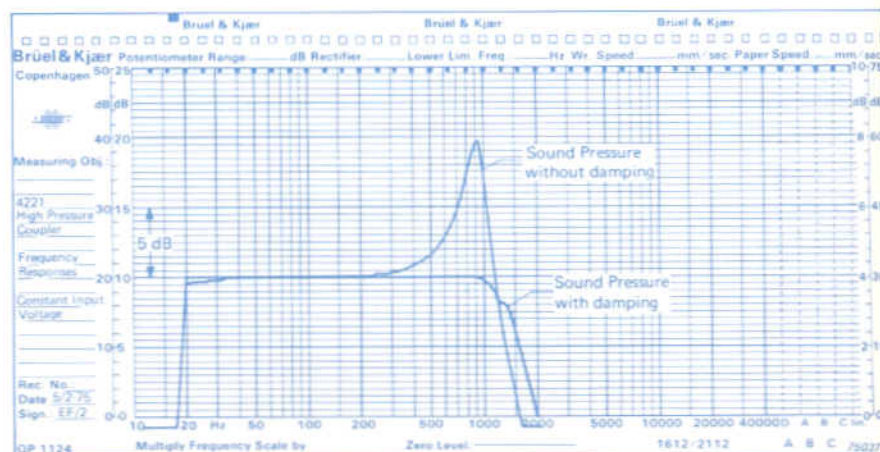

Fig.3. Pressure response curves for the High Pressure Coupler

If the signal from one of two microphones inserted in the coupler is used as a feed-back signal to control the output voltage of the oscillator, the frequency range with closed coupler can be extended up to 1 kHz with lower distortion than when the damping is introduced. The use of the damping, however, gives a simpler measuring set-up, more suitable for field calibration.

The maximum obtainable sound pressure level is, with damping, 154 dB and with limitations in the frequency range, up to 164 dB. The lower frequency limit at this high pressure is raised to about 30 Hz, due to the larger piston displacement, and the upper limit is lowered from 1 kHz to 600 Hz, due to nonlinearity in the acoustic damping resistors. With closed coupler, the lower frequency limit is dependent on air leakage and is not specified as this coupler cannot be used for low frequency calibration (below 3 Hz) which requires that the entire microphone, including its equalization vent, is subjected to the dynamic pressure.

Low Frequency Coupler

For measurements at low frequencies, the special, low frequency coupler delivered with the system is used. This coupler (see Fig.4) is equipped with an equalization vent giving it a low frequency cut-off at 0.1 Hz (-1 dB), but can easily be completely sealed to allow measurements theoretically down to static pressure. The microphone, or other transducer, is mounted inside the coupler while the preamplifier is mounted on the outside. The coupler is equipped with mounting threads for the B & K 1", 1/2" and 1/4" microphones, while 1/8" cartridges are mounted by means of an adaptor, included. The volume of this coupler is approximately 10 cm³ with a 1/2" microphone mounted. The resonant frequency, which depends on the ratio between the system mass and stiffness and the air stiffness of the coupler, is between 350 Hz and 550 Hz at 1013 mbar static pressure, depending on the size of the microphone mounted in the coupler.

Theoretically, the system has a linear frequency response down to static pressure when the equaliza-

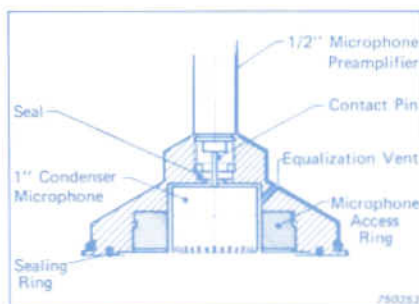

Fig.4. Sectional drawing of the low frequency coupler with a 1/2" microphone mounted

tion vent is sealed but minute air leakage gives it a lower limit between 10⁻³ and 10⁻⁴ Hz. When delivered, the system is controlled to have less than 1 dB decrease in SPL at 10⁻² Hz.

Due to the high equivalent volume of the system (180 cm³) compared to the small coupler volume of max. 10 cm³ (1/2" microphone), the sound pressure is only very little influenced by the change from an adiabatic process to an isothermic process.

Individual Calibration

The High Pressure Microphone Calibrator Type 4221 is delivered with four individual calibration charts. Three of the charts give the sound pressure and reference voltage across the built-in resistor as a function of frequency with a constant voltage applied to the system. The three charts are for: 1) the high pressure coupler undamped, 2) the high pressure coupler damped and 3) the low frequency coupler. The fourth chart gives calibration documentation for the low frequency coupler at 0.3; 0.1; and 0.03 Hz. The charts serve as documentation, and calibration values for use of the system above the linear range can be taken from the charts.

Measuring Set-Ups

Using High Pressure Coupler

Fig.5 shows a typical measuring set-up for measuring frequency response and linearity of condenser mi-

crophones. The oscillator 1027 supplies a swept-sine signal to the calibrator, via the Power Amplifier Type 2706, which can drive the calibrator to full rating, 164 dB SPL. Using the Gating System Type 4440, toneburst techniques can be employed and the maximum sound pressure raised to 172 dB. A SPL of 155 dB can be obtained without the use of a power amplifier if an oscillator 1023 is used. The signal from the microphone under test is measured by the Measuring Amplifier Type 2610 and recorded directly on frequency calibrated paper on the Level Recorder.

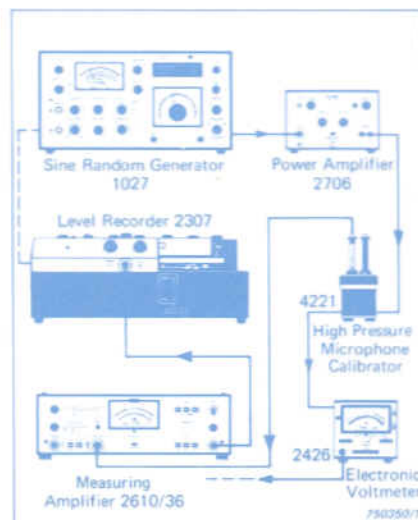

Fig.5. Set-up for automatic frequency response recording of microphones

The sound pressure in the coupler is measured on the Electronic Voltmeter Type 2426 using the calibration value delivered with the calibrator, nominal 20 Pa/mV. As indicated, the output from the voltmeter can also be recorded. For distortion measurements, the oscillator and measuring amplifier could be replaced by, for instance, a Heterodyne Analyzer Type 2010, or a Heterodyne Slave Filter Type 2020 could be connected external to the Measuring Amplifier. Adding a Tracking Frequency Multiplier Type 1901 to either of the set-ups for distortion measurements would allow direct recording of single harmonics as a function of frequency.

Using Low Frequency Coupler

Fig.6 shows a typical measuring

set-up for measurements on low frequency condenser microphones. It utilizes the Microphone Carrier System Type 2631, which works with a carrier frequency of 10 MHz instead of a DC polarization voltage. The B & K 1/2" condenser microphone Type 4147 is specially developed for use with this system for measurements at very low frequencies. An adaptor UA 0030 should

be used with 1" microphones and an adaptor UA 0271 (included with 2631) should be used with 1/2" microphones. The DC output from the system is recorded by a Level Recorder 2307 used in its DC mode — with an external DC bias — as a direct waveform recorder. The sound pressure in the coupler is, in this case, monitored on an oscilloscope via the drive coil current.

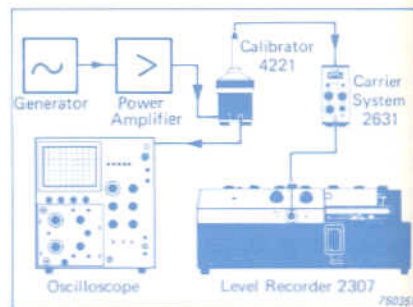

Fig. 6. Set-up for recording low frequency response of microphones

Specifications 4221

<p>BASIC UNIT, ELECTRODYNAMIC SYSTEM</p> <p>Coil resistance: 3 Ω</p> <p>Input current: (continuous operation at 25°C) Max. 1.8 A RMS</p> <p>Input Power: (continuous operation at 25°C) Max. 12 W</p> <p>Magnetic field: Columax permanent magnet</p> <p>Pressure/Current constant: Approx. 1800 Pa/A</p> <p>Pressure/Insert Voltage constant: (adjusted) 20 Pa/mV</p> <p>Adjustment accuracy, 95 Hz — 124 dB: $\pm 0,3$ dB</p> <p>Int. resistance at voltmeter plug: Approx. 25 Ω</p> <p>Moving System: Acoustical Compliance: $1,3 \times 10^{-9} \text{ m}^5/\text{N}$ Acoustical Mass: 2100 kg/m⁴ Resonant Frequency: 95 Hz Diameter of piston: 55 mm</p>	<p>Frequency Range (± 1 dB): 3 Hz to 300 Hz</p> <p>Frequency Range with compressor microphone: 3 Hz to 1000 Hz</p> <p>Harmonic Distortion below 150 Hz and 154 dB: < 0,6%</p> <p>Harmonic Distortion below 150 Hz and 164 dB: < 2%</p> <p>Vibration Level at microphone position at 154 dB and 100 Hz: (is proportional to the SPL and to the square of the frequency) Approx. 0,01 m/s²</p> <p>Sound Pressure Level: (tone burst operation; 15% duration) Up to 170 dB (172 dB for max. 10 minutes)</p> <p>B. WITH DAMPING: OPEN</p> <p>Sound Pressure Level: (continuous operation) Up to 162 dB (164 dB for max. 10 minutes)</p> <p>Correction of Pressure/Insert Voltage constant, 95 Hz: $-0,4 \text{ dB} \pm 0,2 \text{ dB}$</p>	<p>Vibration level at microphone position at 154 dB and 100 Hz: (is proportional to the SPL and to the frequency) Approx. 0,08 m/s²</p> <p>BASIC UNIT WITH LOW FREQUENCY COUPLER (10 cm³)**</p> <p>Sound Pressure Level: (continuous operation) Up to 162 dB (164 dB for max. 10 minutes)</p> <p>Correction of Pressure/Insert Voltage constant, 95 Hz: 0 dB</p> <p>Influence of ambient pressure at 95 Hz: 0,04 dB/100 mbar</p> <p>Frequency Range (specified*): (+ 0 dB — 1 dB re. 95 Hz) 0,01 Hz to 95 Hz</p> <p>Vibration Level at Microphone pos. at 154 dB and 100 Hz: (is proportional to the SPL and to the square of the frequency) Approx. 0,05 m/s²</p> <p>GENERAL</p> <p>Total weight (including Mahogany case): 5,2 kg (11,5 lb)</p>
<p>BASIC UNIT WITH HIGH PRESSURE COUPLER (2 cm³)**</p> <p>Accepts all B & K 1", 1/2", 1/4" and 1/8" microphones; two may be mounted at the same time</p> <p>A. WITHOUT DAMPING: CLOSED</p> <p>Sound Pressure Level: (continuous operation) Up to 162 dB (164 dB for max. 10 minutes)</p> <p>Correction of Pressure/Insert Voltage constant, 95 Hz: 0 dB</p> <p>Influence of ambient pressure at 95 Hz: 0,02 dB/100 mbar</p> <p>Influence of temperature at 95 Hz: Typically < 0,01 dB/°C between -10°C and $+55^\circ\text{C}$</p>	<p>Influence of ambient pressure at 95 Hz: < 0,04 dB/100 mbar</p> <p>Influence of temperature at 95 Hz: Typically < 0,01 dB/°C between -10°C and $+55^\circ\text{C}$</p> <p>Frequency Range ($\pm 2,0$ dB) below 154 dB: 20 Hz to 1000 Hz</p> <p>Frequency Range ($\pm 2,0$ dB) below 164 dB: 30 Hz to 500 Hz</p> <p>Harmonic Distortion below 154 dB (20 Hz to 150 Hz): < 2%</p> <p>Harmonic Distortion below 164 dB (40 Hz to 150 Hz): < 2%</p>	<p>Accessories included:</p> <ol style="list-style-type: none"> 1 Low Frequency Coupler UA 0500 1 High Pressure Coupler UA 0499 2 Adaptors for B & K 1/2" Microphones UA 0498 2 Adaptors for 1/4" Microphones UA 0497 2 Adaptors for 1/8" Microphones UA 0496 2 Springholders for 1/2" Preamplifiers UA 0495 2 Springholders for 1/4" Preamplifiers UA 0494 1 Preamplifier Dummy DP 0189 1 Cable, BNC to B & K AO 0064 1 Cable, BNC to B & K with separate ground AO 0127 1 Threaded Adaptor for 1/4" — 1/8" UA 0501 <p>** Specifications valid: at 1013 mbar ambient pressure * In principle the system works down to even lower frequencies, in fact to static pressures; but uncontrolled leakages may be expected to cause a lower limiting frequency of 0,1 mHz to 1 mHz</p>