

## 1/2" Condenser Microphone Cartridge Microphone Preamplifier and Microphone Power Supply

types 4130, 2642 and 281

### FEATURES:

#### Microphone Type 4130

- Sensitivity 10 mV/Pa (-40 dB re 1 V/Pa) with 28 V polarization voltage
- Frequency range from 5 Hz to 12,5 kHz  $\pm 3$  dB
- Dynamic range from 13,5 to 142 dB (A-weighted noise floor to 3 % distortion limit)
- Low temperature coefficient
- Low polarization voltage
- Rugged construction
- High resistance to humidity
- Conforms to:  
IEC 651, Type 2  
ANSI S1.4 - 1971, Type 2\*

#### Preamplifier Type 2642

- Frequency range from 20 Hz to 20 kHz  $\pm 1$  dB
- Wide dynamic range
- Low noise
- High input impedance
- Small size and robust construction

These instruments are designed for use in low cost, simple and flexible general purpose sound measurement systems

The 1/2" Condenser Microphone Cartridge Type 4130 is a robust, quality transducer which is primarily intended for use with B & K Dosimeters and with the 1/2" Microphone Preamplifier Type 2642. The 4130/2642 combination yields a compact, rugged assembly for operation in the harsh environment of industry.

The Microphone Power Supply Type 2810 is a battery operated unit with two independent channels. It supplies the necessary operating voltages for driving two Type 2642/4130 assemblies.

\* and proposed revision of this standard

#### Power Supply Type 2810

- Two identical channels
- Built-in amplifiers with frequency range from 10 Hz to 15 kHz  $\pm 1$  dB
- Separately adjustable gain controls with 0 to +40 dB range
- Battery powered
- Long battery lifetime (approx. 200 hours continuous operation with two 2642s)
- Lightweight, compact construction

### USES:

- Noise measurements to IEC 651, Type 2 and ANSI S1.4 - 1971, Type 2\*
- Noise monitoring
- Sound insulation measurements
- Sound transmission measurements
- Sound power measurements
- Quality control measurements
- General sound measurements

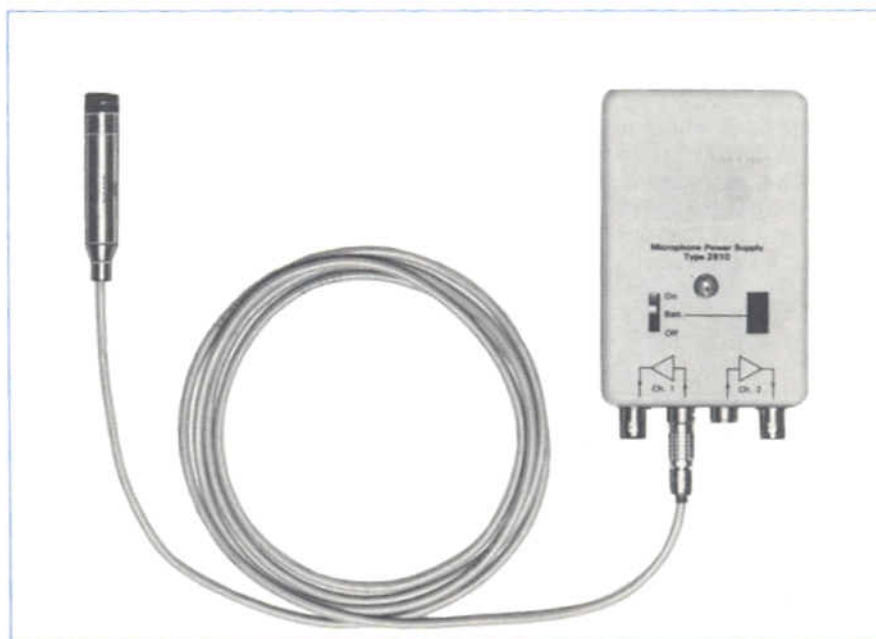

Together, the 4130, 2642 and 2810 constitute a completely self-contained, low cost microphone system for general monitoring purposes. This combination is compatible with the wide variety of portable instruments available from B & K for measuring, recording and analyzing sound, and may also be used as part of a multichannel data acquisition system.



Fig. 1.  $\frac{1}{2}$ " Condenser Microphone Type 4130 and Random Incidence Corrector DZ 9566

## Description

### Microphone Type 4130

The  $\frac{1}{2}$ " Condenser Microphone Type 4130, shown in Fig. 1., is a low cost, robust microphone which connects directly to Microphone Preamplifier Type 2642 and is well suited for use in the environments of factories and workshops. It has a wide temperature range, very low variation in sensitivity with ambient temperature and good resistance to humidity, as well as the high long-term stability normally associated with this type of condenser microphone.

The Microphone is equipped with a robust, non-removable protection grid which is finished in wear resistant, matt black chrome. The grid is fitted internally with a gauze filter which affords excellent protection from dust and particle penetration to the diaphragm. In addition, the diaphragm is coated with a very thin, corrosive resistant polymer film.

The 4130 has a linear,  $0^\circ$  incidence free-field frequency response, compensating for the pressure increase in front of the microphone which occurs at high frequencies due to the presence of the microphone itself in the sound field. In addition, Type 4130 is supplied with a Random Incidence Corrector DZ 9566. This Corrector, which is fitted over the normal protection grid of the Microphone, results in a linear frequency response under diffuse field conditions. Fig. 2. shows the free-field response curve for the 4130 together with random incidence responses both with and without the Corrector DZ 9566.

\* and proposed revision of this standard

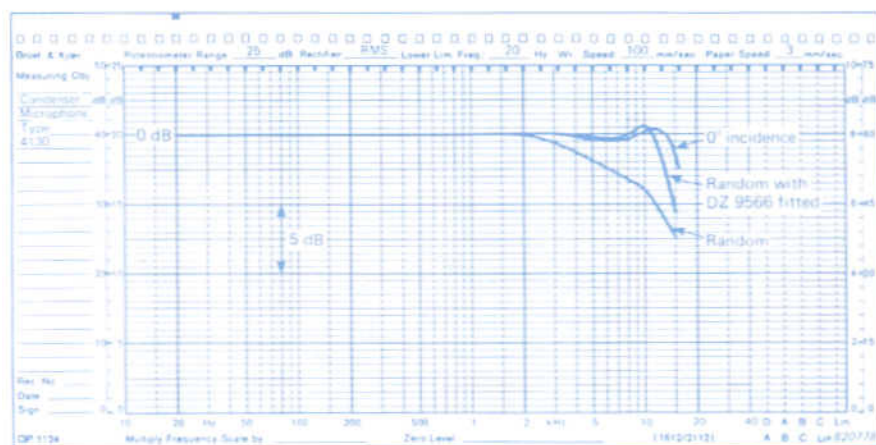

Fig. 2. Typical frequency response characteristics of Type 4130

The Microphone conforms to IEC 651, Type 2 and ANSI S1.4 - 1971, Type 2\*, the latter when fitted with Random Incidence Corrector DZ 9566. Each Microphone is delivered with a calibration chart giving the individually measured open circuit sensitivity and typical frequency response curves.

The lower frequency limit of a microphone is determined by the time constant of the static pressure equalization vent, which in the 4130 is adjusted to lie in the range 0.32 to 0.032 s, giving a lower limiting frequency ( $-3$  dB) between 0.5 and 5 Hz.

The pressure equalization vent of the 4130 is led to the rear of the cartridge, permitting the use of the  $\frac{1}{2}$ " Dehumidifier UA 0308. The UA 0308 dries the air inside the microphone, enabling the 4130 to be used for measurements in very humid environments.

The Microphone is designed for use with low polarization voltages (nominally 28 V), but may be used with up to 120 V polarization to give an increase in sensitivity if the corresponding changes in the Microphone response are acceptable. When used in conjunction with Types 2642 and 2810 a polarization voltage of 28 V is used, thereby maintaining nominal sensitivity of 10 mV/Pa ( $-40$  dB re 1 V/Pa).

### Preamplifier Type 2642

The Microphone Preamplifier Type 2642 (Fig. 3.) may be used with  $\frac{1}{2}$ " Condenser Microphone Type 4130



Fig. 3.  $\frac{1}{2}$ " Microphone Preamplifier Type 2642

and other B & K  $\frac{1}{2}$ " Condenser Microphones, which are fitted directly to the 2642. For full information of the range of B & K Condenser Microphones, see separate Product Data sheets.

The Preamplifier operates as an impedance converter for driving long cables and has a linear frequency response from 20 Hz to 20 kHz  $\pm 1$  dB with a capacitance of 15 pF connected to the input (approximately equivalent to the capacitance of B & K  $\frac{1}{2}$ " Condenser Microphones).

The power for the Preamplifier and polarization voltage for the microphone are supplied via a 2 m long screened cable terminated with a 5-pin plug JP 0510, which connects directly to the battery operated Microphone Power Supply Type 2810.

Extension Cables AO 0175, AO 0176 and AO 0177 (3, 10 and 30 m length respectively) are available for connection between the 2642 and the 2810. The capacitance of these cables is 0.36 nF, 1.6 nF, and 3.6 nF respectively and the influence of load capacitance (cable length) on the frequency range of the Preamplifier can be seen in Fig. 6.

The Preamplifier can also be powered via the standard seven-pin preamplifier input socket of B & K Spectrometers, Analyzers and Measuring Amplifiers using the Seven-pin Adaptor JP 0713. As supplied, the Adaptor also modifies the 200 V DC

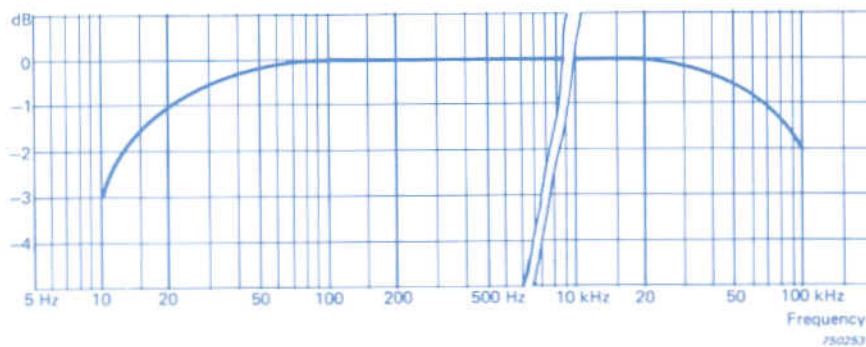

Fig. 4. Typical frequency response of Type 2642 with capacitance of 15 pF connected to the Preamplifier input

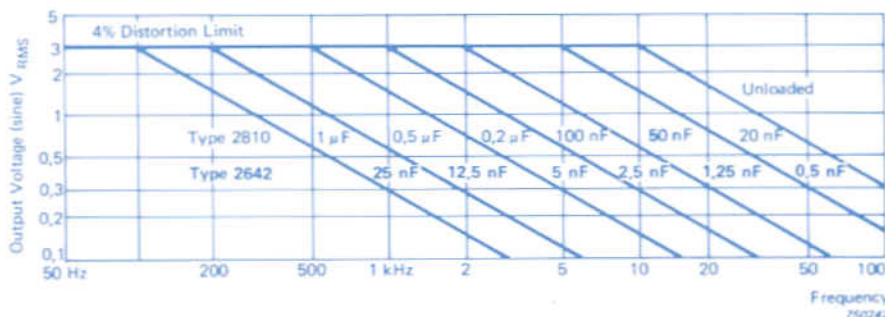

Fig. 6. Upper limit of dynamic range of Type 2642 and 2810 as a function of capacitive loading

polarization voltage to the 28 V DC required for Type 4130.

A small, 65 mm diameter, Wind-screen UA 0459 is supplied with the 2642 for use on  $\frac{1}{2}$ " Microphones during outdoor measurements.

#### Power Supply Type 2810

The Microphone Power Supply Type 2810, shown in Fig. 5., is battery operated and has two channels with individual amplifiers providing a high level signal for further processing. It supplies the necessary powering and polarization voltages for two 2642/4130 combinations.

The built-in amplifiers have a frequency range from 10 Hz to 15 kHz  $\pm 1$  dB with individually adjustable gain over a range from 0 to 40 dB. The output impedance is low, allowing the use of long cables between the 2810 and following measuring equipment. Fig. 6. shows the upper limit of the dynamic range as a function of cable capacitive load (cable length) on the output.

The 2810 is equipped with standard BNC output sockets for easy connection to other equipment.

The polarization voltage supplied from the 2810 is 28 V, allowing the use of  $\frac{1}{2}$ " Condenser Microphones Types 4130 and 4148 while maintaining their nominal sensitivity. When the 2810/2642 combination is used with

other  $\frac{1}{2}$ " microphones normally requiring 200 V polarization voltage, the sensitivity of these microphones is reduced by approximately 17 dB and the frequency response is changed.

The 2810 is powered from four 9 V alkaline batteries (IEC type 6LF22, order no. QB 0016). A three position switch with "On", "Off" and "Batt." (battery check) positions is situated on the front plate together with a LED indicator for checking the supply voltage. The Power Supply will operate continuously for approximately 200 hours on one set of alkaline batteries when powering two 4130/2642 assemblies.

#### Calibration

For calibration of the 4130, 2642 and 2810 combination and following measuring equipment, the Sound Level Calibrator Type 4230 or Piston-

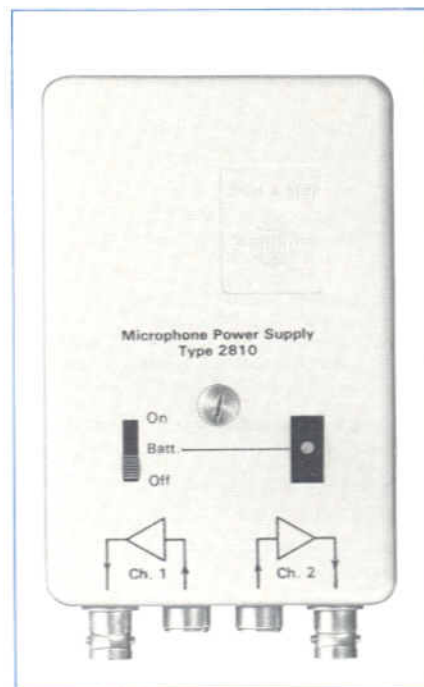

Fig. 5. Microphone Power Supply Type 2810

phone Type 4220 are available. The 4230 calibrates at 1 kHz (and is therefore independent of any frequency weighting) with a sound pressure level of  $94 \text{ dB} \pm 0.3 \text{ dB}$ , while the 4220 supplies a SPL of  $124 \pm 0.2 \text{ dB}$  at 250 Hz. Both Calibrators are battery operated and easy to use.

#### Application Examples

These three instruments constitute a portable, self-contained, battery powered microphone system which can be used in a wide range of sound and noise measurement such as sound power measurements, sound insulation and transmission measurements, noise monitoring, quality control and general purpose sound measurements. The system can be used with a wide range of B & K portable equipment for tape or graphic recording of noise, for example as shown in Fig. 7.

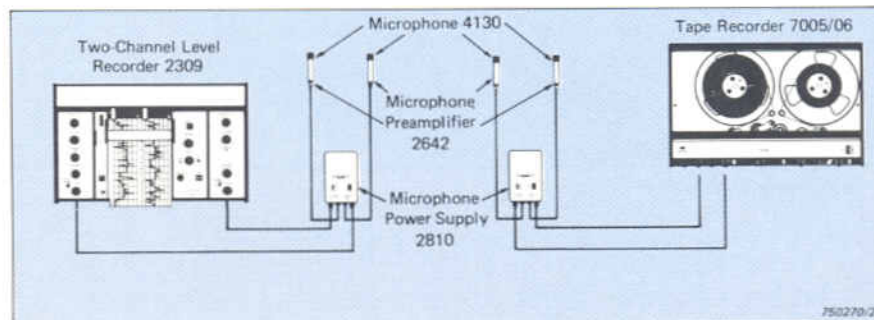

Fig. 7. Examples of portable instrument combinations. When the Componder Unit ZM 0054 is used with the Tape Recorders, the 2642 may be connected directly

# Specifications 4130, 2642, 2810

<b>MICROPHONE TYPE 4130</b>		
<p><b>OPEN CIRCUIT SENSITIVITY:</b> 10 mV/Pa (-40 ± 1,5 dB re 1 V/Pa) at 250 Hz, 28 V DC polarization</p> <p><b>FREQUENCY RESPONSE:</b> <b>0° Incidence Free-field Response:</b> 6,5 Hz to 8 kHz ± 2 dB 5 Hz to 12,5 kHz ± 3 dB In accordance with IEC 651, Type 2</p> <p><b>Random Incidence Response:</b> In accordance with ANSI S1.4 - 1971, Type 2* when fitted with Random Incidence Corrector DZ 9566</p> <p><b>LOWER LIMITING FREQUENCY (-3 dB):</b> 0,5 to 5 Hz</p> <p><b>CARTRIDGE THERMAL NOISE:</b> 13,5 dB(A)</p> <p><b>OPEN CIRCUIT DISTORTION LIMIT (3%):</b> 142 dB SPL</p> <p><b>SAFETY LIMIT:</b> 156 dB peak</p>	<p><b>DIAPHRAGM RESONANCE FREQUENCY (90° PHASE SHIFT):</b> 12,5 kHz</p> <p><b>MAXIMUM POLARIZATION VOLTAGE:</b> 120 V DC</p> <p><b>POLARIZED CARTRIDGE CAPACITANCE:</b> 14 pF at 250 Hz, 28 V polarization</p> <p><b>OPERATING TEMPERATURE RANGE:</b> up to +100 °C (+212 °F) up to +70 °C (+158 °F) when fitted with Random Incidence Corrector DZ 9566</p> <p><b>AMBIENT TEMPERATURE COEFFICIENT:</b> -0,007 dB/°C Mean for the range -10 to +50°C</p> <p><b>LONG TERM STABILITY AT 20 °C:</b> &gt;250 years/dB</p> <p><b>EQUIVALENT AIR VOLUME:</b> 50 mm<sup>3</sup></p> <p><b>INFLUENCE OF STATIC PRESSURE:</b> -0,002 dB/mbar</p>	<p><b>INFLUENCE OF 1 m/s<sup>2</sup> AXIAL VIBRATION:</b> Typically 60 dB equivalent SPL</p> <p><b>INFLUENCE OF 80 A/m, 50 Hz MAGNETIC FIELD:</b> Typically 30 dB equivalent SPL</p> <p><b>INFLUENCE OF RELATIVE HUMIDITY:</b> &lt;0,1 dB in the absence of condensation</p> <p><b>DIMENSIONS:</b> <b>Overall Diameter with Protection Grid:</b> 13,2 mm <b>Cartridge Housing Diameter:</b> 12,7 mm <b>Height:</b> 14,9 mm <b>Diameter with Corrector DZ 9566:</b> 14,35 mm <b>Height with Corrector DZ 9566:</b> 16,7 mm</p> <p><b>ACCESSORIES INCLUDED:</b> 1 Random Incidence Corrector..... DZ 9566</p> <p><b>ACCESSORIES AVAILABLE:</b> Sound Level Calibrator ..... Type 4230 Pistonphone ..... Type 4220 1/2" Dehumidifier ..... UA 0308 Set of 6 Windscreens (UA 0459)..... UA 0469</p>
<b>PREAMPLIFIER TYPE 2642</b>		
<p><b>FREQUENCY RESPONSE:</b> 20 Hz to 20 kHz ± 1 dB</p> <p><b>INPUT IMPEDANCE:</b> Typically 1 GΩ//3 pF</p> <p><b>MAXIMUM INPUT VOLTAGE:</b> 100 V RMS at 50 Hz</p> <p><b>OUTPUT IMPEDANCE:</b> Typically 1,6 kΩ</p> <p><b>DISTORTION:</b> See Fig. 6</p> <p><b>MAXIMUM OUTPUT VOLTAGE:</b> 4,5 V peak</p>	<p><b>MAXIMUM OUTPUT CURRENT:</b> 100 μA peak</p> <p><b>ATTENUATION:</b> &lt;3,0 dB</p> <p><b>NOISE:</b> <b>A-weighted:</b> Typically 3,5 μV RMS <b>Lin. 22,5 Hz to 22,5 kHz:</b> Typically 12 μV RMS</p> <p><b>OPERATING VOLTAGE:</b> 30 to 36 V</p> <p><b>TEMPERATURE RANGE:</b> <b>Operation:</b> -10 to +50 °C (+14 to +122°F) <b>Storage:</b> -20 to +70 °C (-4 to +158 °F)</p>	<p><b>DIMENSIONS:</b> <b>Diameter:</b> 12,7 mm (0,5 in) <b>Length:</b> 55 mm (2,1 in) <b>Integral Cable Length:</b> 2 m (6,6 ft) terminated in 5-pin Plug JP 0510</p> <p><b>ACCESSORIES INCLUDED:</b> 1 Windscreen ..... UA 0459</p> <p><b>ACCESSORIES AVAILABLE:</b> Microphone Power Supply ..... Type 2810 Seven-pin Adaptor ..... JP 0713 Extension Cable (3 m) ..... AO 0175 Extension Cable (10 m) ..... AO 0176 Extension Cable (30 m) ..... AO 0177</p>
<b>MICROPHONE POWER SUPPLY TYPE 2810</b>		
<p><b>FREQUENCY RESPONSE:</b> 10 Hz to 15 kHz ± 1 dB</p> <p><b>AMPLIFIER GAIN:</b> Adjustable from 0 to +40 dB ± 0,5 dB</p> <p><b>INPUT SOCKETS:</b> 5 pin socket supplying preamplifier power and 28 V microphone polarization. Accepts plug JP 0510.</p> <p><b>INPUT IMPEDANCE:</b> &gt;40 kΩ</p> <p><b>MAXIMUM INPUT VOLTAGE:</b> 100 V peak to peak</p> <p><b>OUTPUT IMPEDANCE:</b> 100 Ω in series with 6,8 μF</p> <p><b>DISTORTION:</b> See Fig. 6</p>	<p><b>MAXIMUM OUTPUT VOLTAGE:</b> 4,5 V peak</p> <p><b>MAXIMUM OUTPUT CURRENT:</b> 3 mA</p> <p><b>CHANNEL SEPARATION:</b> &gt;70 dB at 10 kHz</p> <p><b>NOISE:</b> Referred to input at max. gain <b>A-weighted:</b> Typically 2,5 μV RMS <b>Lin. 22,5 Hz to 22,5 kHz:</b> Typically 4 μV RMS</p> <p><b>INFLUENCE OF 100 A/m, 50 Hz MAGNETIC FIELD:</b> Max. 3 mV RMS output</p> <p><b>POWER SUPPLY:</b> Four 9 V DC alkaline batteries, IEC type 6LF 22 (QB 0016). Approximately 200 hours continuous operation with two 2642s</p>	<p><b>TEMPERATURE RANGE:</b> <b>Operation:</b> -10 to +50 °C (+14 to +122 °F) <b>Storage:</b> -20 to +70 °C (-4 to +158 °F) with batteries removed</p> <p><b>DIMENSIONS:</b> Including sockets <b>Length:</b> 127 mm (5 in) <b>Width:</b> 75 mm (3 in) <b>Height:</b> 37 mm (1,4 in)</p> <p><b>WEIGHT:</b> 350 g (12,5 oz) including batteries</p> <p><b>ACCESSORIES INCLUDED:</b> 4 Alkaline Cells (IEC 6LF 22) ..... QB 0016 1 Screwdriver ..... QA 0027 1 Screwdriver ..... QA 0001</p>

\* and proposed revision of this standard